

**SONY®**

**STEREO PREAMPLIFIER**

**TAE-5450**

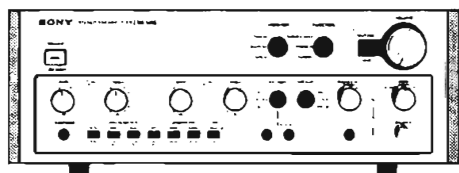

**Owner's Instruction Manual**

© 1976 by Sony Corporation

To derive the utmost in pleasure and utility from your Sony TAE-5450, please read this manual completely to become familiar with all its features and capabilities. Keep this manual handy for future reference.

## TABLE OF CONTENTS

Warning . . . . .	2
Unpacking . . . . .	2
Precautions. . . . .	3
System Connections . . . . .	3
Connection notes	
Power connection	
Power amplifier connection	
Connection diagram	
Program source connections	
Ground connection	
Operating Instructions . . . . .	6
Initial operation	
Sound adjustments	
Tape recording	
Front Panel Facilities . . . . .	7
General control section	
Tone control section	
Input selection section	
Add-on accessory section	
External Adaptor Connectors . . . . .	10
Care of Your Equipment . . . . .	10
Trouble checks	
Cleaning	
Specifications . . . . .	11
Block Diagram . . . . .	back cover

## UNPACKING

Do not throw away the TAE-5450 carton and the associated material; they will come in handy if you ever have to transport or ship your set. Inspect your TAE-5450 immediately after unpacking.

If any sign of damage is found, consult your local Sony dealer. When shipping the set for repair work or to another location, the set should be repacked in the original carton and packing material just as before.

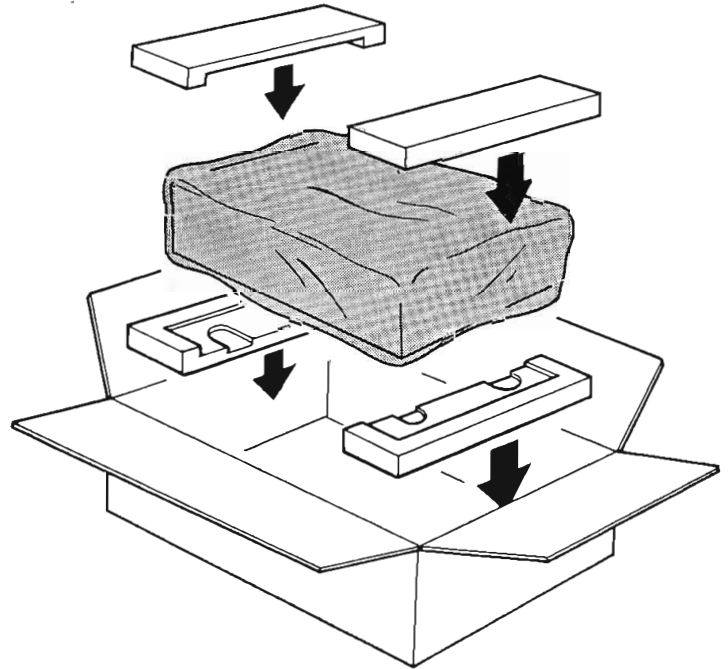

## WARNING

- To avoid electrical shock, do not open the cabinet.

Refer servicing to qualified personnel only.

- To prevent fire or shock hazard, do not expose the set to rain or moisture.

## PRECAUTIONS

Correct installation and proper operation contribute both to your safety and to the continued trouble-free operation of your TAE-5450. Particular attention should be paid that your installation and operating procedures comply with the following requirements.

- Operate the amplifier only on 120 V ac 60 Hz.
- Do not overload the outlet from which your music system operates by simultaneously using high wattage devices such as electric irons or hair dryers.
- Good air circulation is essential to prevent internal heat build-up in the TAE-5450. Place the set in a location with adequate air circulation. Don't place the set on soft surfaces such as a rug that would block the ventilation holes on the bottom.
- Don't place anything on top of the cabinet. The top ventilation holes must be unobstructed for the proper operation of the preamplifier and to prolong the life of its components.
- Don't install the TAE-5450 in a location near heat sources such as radiators or air ducts, or in a place subject to direct sunlight, excessive dust, mechanical vibration or shock.
- Unplug the set from the wall outlet if it is not to be used for an extended period of time.
- To disconnect the cord, pull it out by grasping the plug. Never pull it by the cord.
- Before making connections, be sure to turn the power switch off.
- Should any liquid or foreign objects fall into the cabinet, turn off the power switch, unplug the set and have it checked by your Sony dealer before operating.
- When the set is not in use, turn the power off to conserve energy and to extend the useful life of your equipment.
- If any problem arises in the operation of this set, such as no sound from one or both channels, etc., first follow the procedures suggested in "TROUBLE CHECKS" on page 10. Most problems that arise are the result of a simple misconnection or incorrect operation and can be cleared up easily. If the difficulty still persists, contact your nearest Sony dealer.

## SYSTEM CONNECTIONS

### CONNECTION NOTES

- To assure correct matching at the input and output terminals of your audio system, refer to the "SPECIFICATIONS" on page 11, and to the specifications given in the instruction manuals provided with the components you wish to connect to the TAE-5450. Generally the output level of a signal source (phono cartridge, tape recorder, etc.) should be equal to or slightly greater than the sensitivity of the corresponding input. Also the output impedance of a signal source should be considerably lower than the impedance of the corresponding input. For example, a tape recorder having an output level and impedance of 250 millivolts and 10,000 ohms respectively can be connected to the TAE-5450 TAPE inputs which are rated at 150 millivolts and 50,000 ohms.
- For all program source input and output connections, use a low-capacitance type shielded cable. Keep the cables as short as practicable, avoiding horizontal runs. Excessively-long runs of over 2 meters (6 feet) tend to reduce the high frequency response, while horizontal runs are susceptible to power line hum pickup.
- The cables should be fully inserted into the jacks. A loose connection may cause hum and noise.
- Before reconnections are made, be sure to lower all source level controls and turn off the TAE-5450 to avoid possible speaker damage.

### POWER CONNECTION

Before making any form of power connection, make sure the TAE-5450 POWER switch is OFF. Then plug the ac power cord into a wall outlet.

Receptacles on the TAE-5450 rear panel provide a convenient source of ac power for other system components.

The two SWITCHED outlets are controlled by the front panel POWER switch, and the total power consumption of all equipment plugged into these outlets should not exceed 300 watts. The UNSWITCHED outlet is not controlled by the POWER switch, and supplies ac power up to 200 watts.

- Never run electrical home appliances such as an electric iron, fan, or TV from these outlets.

### POWER AMPLIFIER CONNECTION

Connect the TAE-5450 OUTPUT jacks (1 or 2) to the input jacks of the power amplifier. The rated output level of the TAE-5450 is 1.0 volt.

When using the HEADPHONE jack, the OUTPUT 2 jacks are disconnected, but the OUTPUT 1 jacks remain live.

When the TAE-5450 feeds program material to two sound systems, use OUTPUT 1 for the remote sound system, and OUTPUT 2 for the local system.

In this way you can use the HEADPHONE jack without affecting the remote sound system.

**CONNECTION DIAGRAM**

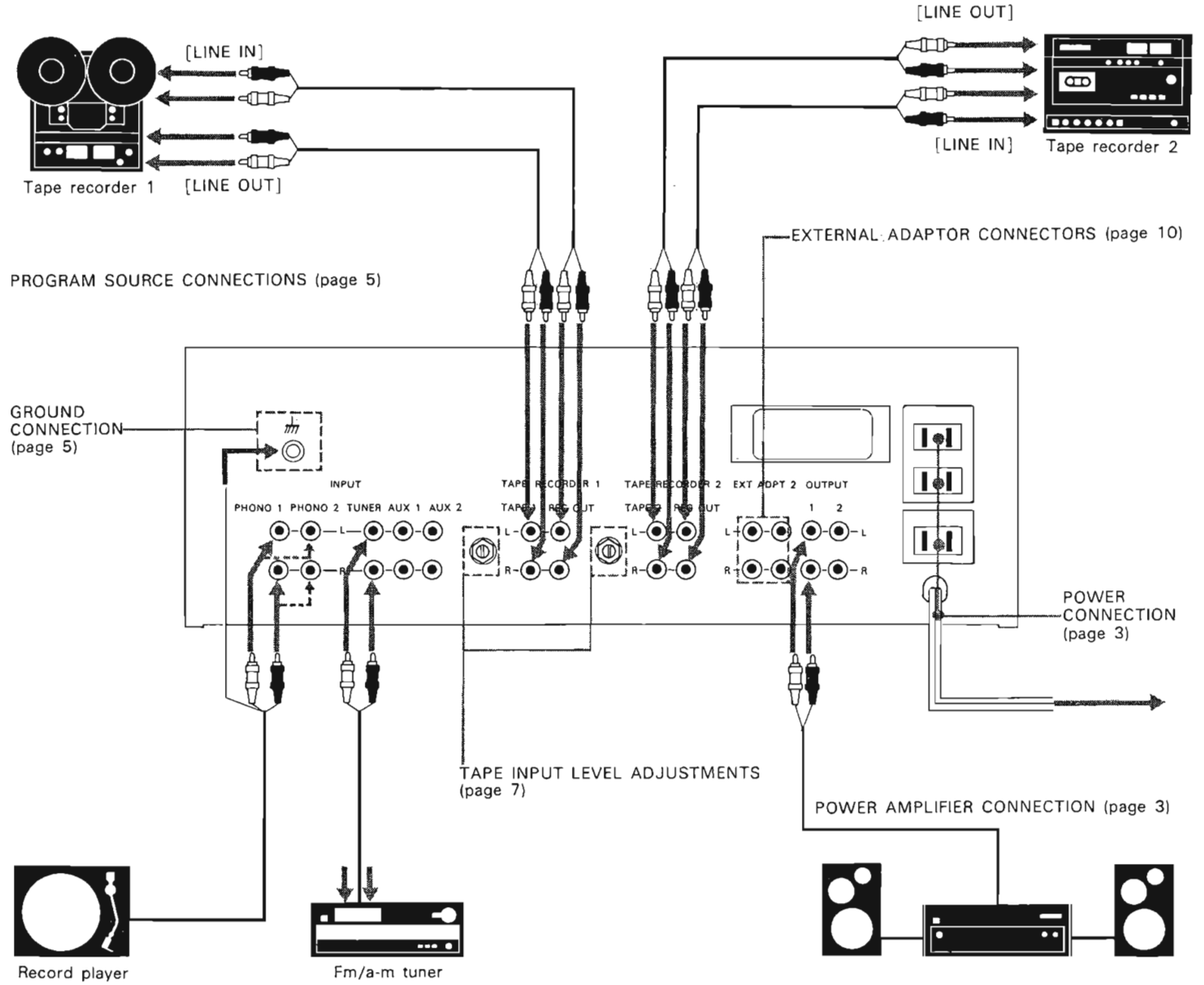

## PROGRAM SOURCE CONNECTIONS

### Record Players

The TAE-5450 features dual phono inputs.

These are convenient for comparing two types of cartridges or record players.

PHONO 1, 2: Accept cartridges having a low-to-medium output. Its phono input sensitivity is 1.5 millivolts and the input impedance is a standard load of 50,000 ohms.

● Insert the shorting plugs (supplied) for muting the phono terminals when these inputs are not in use, to reduce residual noise. Never insert the shorting plugs in any output or input jacks other than the PHONO.

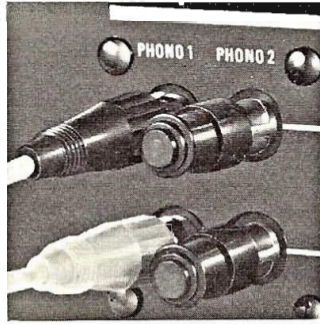

### Tuner

Connect the line outputs of your tuner to the TUNER inputs. The AUX inputs also accept tuner outputs.

(TUNER inputs and AUX inputs are identical in sensitivity and input impedance.)

### Tape Recorders

Two pairs of TAPE RECORDER connectors (1 and 2) are provided. They can be used for direct tape duplication or for making two recordings simultaneously.

TAPE 1 and 2: These are designed for playing back taped programs.

Connect the tape recorder line outputs to the TAPE inputs.

REC OUT 1 and 2: These are designed for tape recording.

Connect the tape recorder line inputs to the REC OUT jacks.

● The signals which are routed to the REC OUT jacks are determined by the front panel TAPE COPY selector described on page 9.

● For tape input level adjustment, refer to page 7.

### Other Input Sources

The AUX (1 and 2) inputs are provided for connecting various input sources such as a cassette player, additional tuner, record player equipped with a ceramic cartridge, and so forth.

The AUX 3 jack on the front panel is convenient for connecting an input source for temporary use.

For this purpose, use the binaural-plug cord (RK-81H) supplied.

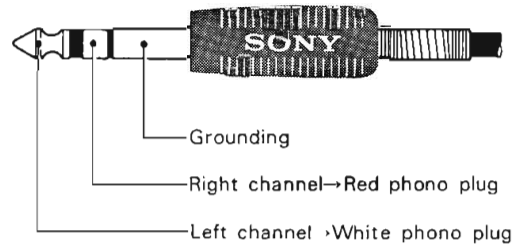

## GROUND CONNECTION

To prevent hum, be sure to connect the ground wire of the record player to the preamplifier ground terminal. If hum still exists, it may be helpful to connect the ground terminal to a good ground such as the plate screw of an ac outlet, a clamp on a cold water pipe, or directly to earth via a ground rod.

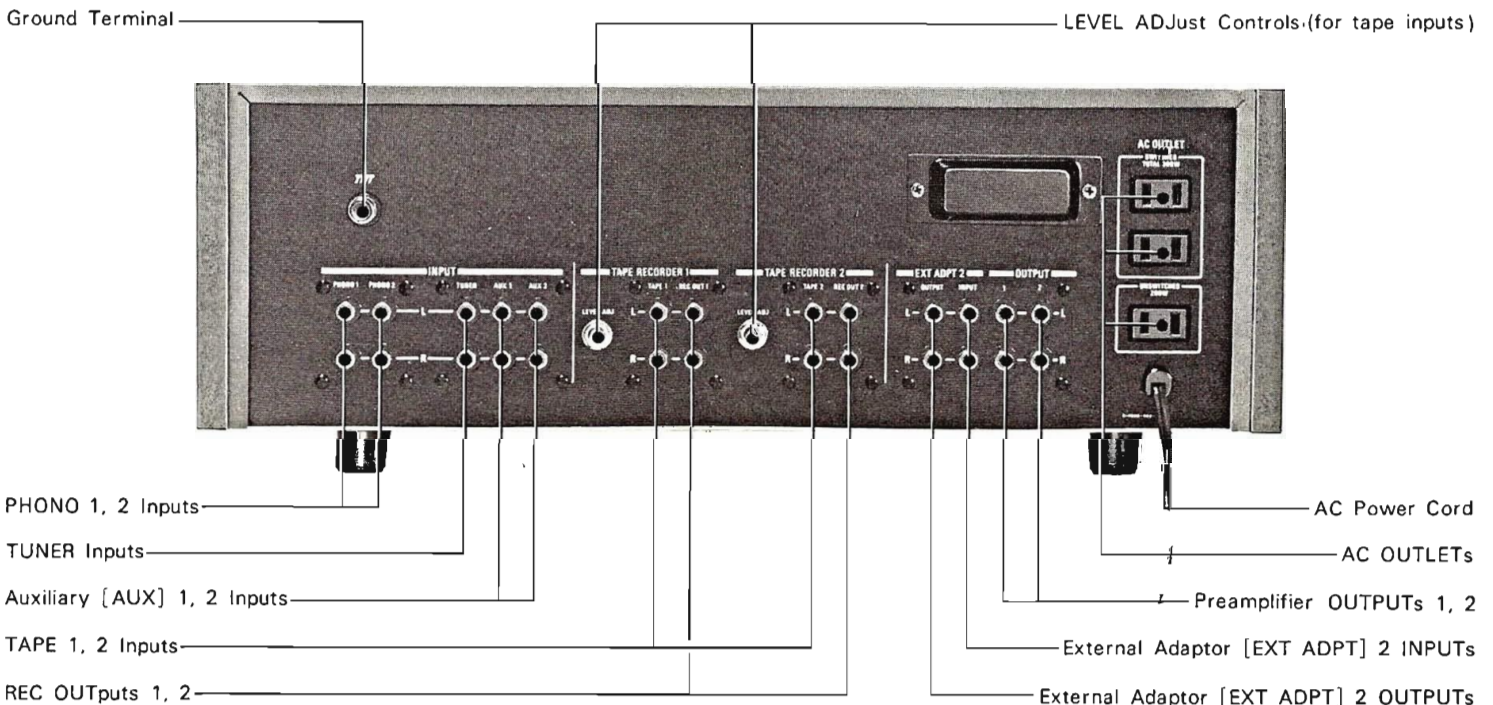

# OPERATING INSTRUCTIONS

## INITIAL OPERATION

As a preliminary to initial operation, check that the POWER switch is released (OFF) and plug the TAE-5450 into a suitable power outlet.

Before proceeding to any type of operation, set the controls and switches as shown below:

- ① Set the VOLUME control at minimum position (fully counter-clockwise).
- ② Select the desired program source.

Program	MONITOR	FUNCTION	PHONO 2/AUX
Fm/a-m tuner	SOURCE	TUNER	—
Record playing		PHONO 1	—
		PHONO 2/AUX	PHONO 2
Auxiliary sources		PHONO 2/AUX	AUX 1~3
Taped program	TAPE 1 or 2	—	—

- ③ Depress the POWER switch to ON.  
(The TAE-5450 employs a muting circuit which provides a 5 - 7 second delay after switch-on to avoid any annoying "thump" noises when the set is first turned on.)

## SOUND ADJUSTMENTS

Now your TAE-5450 is ready for operation.

### Sound Volume

Adjust the VOLUME control to produce the desired level by turning it clockwise, keeping power amplifier and speaker power ratings in mind.

### Stereo Balance

The feeling of direction and depth that stereophonic sound produces is greatly diminished if the levels of both channels are not balanced. Set the MODE selector to L+R and adjust the BALANCE control for equal output from the right and left speakers. Balance variations with different program sources are then due to differences in the recording levels. Stereo balance is also influenced by the acoustics of the room. Carpets, furniture placement, and room size and shape have a definite effect upon sound quality and balance.

### Tone

The manipulation of the tone control section does not interrupt the signal path in the preamplifier. However, its overuse may adversely affect system tone quality. For proper use, refer to "TONE CONTROL SECTION" on page 8.

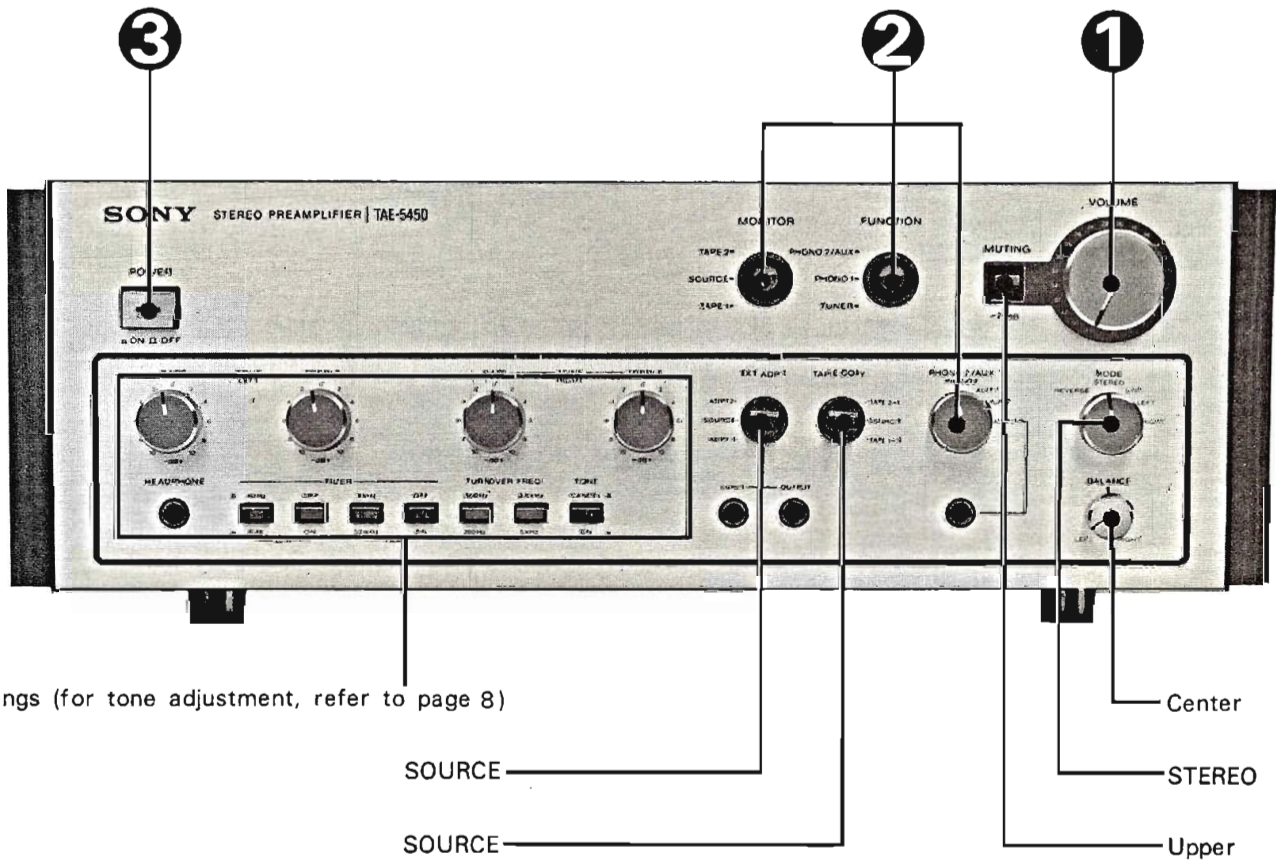

## FRONT PANEL FACILITIES

This section describes the operation and function of each facility on the front panel of the TAE-5450.

### Tape Input Level Adjustment

When you switch from a taped program to another source, differences of sound level sometimes may result because of unequal input levels.

The TAE-5450 has LEVEL ADJ controls for TAPE 1 and 2 inputs to eliminate the need to reset the volume control in such cases. Balance the tape input level as follows:

- ① Set the MODE selector to L+R and turn the VOLUME control to the desired level.
- ② Compare the volume level of each source by switching the input selectors (MONITOR, FUNCTION, PHONO 2/AUX).
- ③ If the taped program is greater in volume level than the other source, turn the LEVEL ADJ control counterclockwise until the same volume level is obtained from each source.
- The LEVEL ADJ controls are factory-preset at maximum (fully clockwise).
- Fully counterclockwise rotation of the LEVEL ADJ controls does not bring the tape inputs down to zero level.

### TAPE RECORDING

- ① Set the MONITOR selector to SOURCE.
- ② Select the recording program with the FUNCTION and PHONO 2/AUX selectors.
- ③ Set the TAPE COPY selector to SOURCE.
- ④ Adjust the recording level at the recorder and start it in record mode.
- The VOLUME, BALANCE, TONE controls, and FILTER switches have no effect upon the recording.

### Monitoring of 3-head Tape Recorder

If your tape recorder has separate record and playback heads, you can monitor the recording results by setting the MONITOR selector to TAPE position.

In this case, the recorder should be connected to the TAPE and REC OUT jacks and its tape monitor should be at the TAPE position.

### GENERAL CONTROL SECTION

#### POWER Switch

Turns the operating power on or off. The switch lights with a soft green glow when the power is on.

#### HEADPHONE Jack

This jack accepts any low or high impedance stereo headphones.

- When this jack is used, the OUTPUT 2 jacks are cut off.

#### VOLUME Control

This precisely matched attenuator control regulates the overall sound level. Note that the "0" indication (the fully clockwise position) means that the volume control provides zero attenuation (full gain amplification). Counterclockwise rotation from "0" to "-34" position lowers the volume in "2 dB" steps, that change in level being considered to be the minimum detectable by the human ear.

- To prevent inadvertent speaker damage, lower the volume before you turn on or shut down the system.

#### BALANCE Control

Regulates the level of either the left or right channel without changing the total sound volume.

When you turn the BALANCE control to the right, left channel volume is decreased, and vice versa.

*For normal operation, set the BALANCE control to the center position.*

#### MODE Selector

Determines the mode of the program reproduced at the OUTPUT 1, 2 and HEADPHONE jacks.

This selector has no effect upon the REC OUT (1, 2) and EXT ADPT OUTPUT jacks.

MODE selector setting	Input	Output	Use
REVERSE	L R	R L	To reverse right and left stereo sound
STEREO	L R	L R	Normal stereo sound
L+R	L R	L R	Mono sound Speaker phasing check Stereo balance
LEFT	L R	L R	To amplify a monaural input source
RIGHT	L R	L R	

#### MUTING Switch

When the MUTING switch is set to -20 dB, the overall listening sound level is reduced by that amount.

This feature is useful when you lower the tonearm onto the disc or when you answer the telephone. When setting it back afterwards, you can restore exactly the same listening level as before.

*For normal operation, set the MUTING switch to the upper position.*

## TONE CONTROL SECTION

### FILTER Switches

ON/OFF switches and cut-off frequency selectors are provided. With the ON/OFF switch released (OFF), the associated FILTER circuit is disconnected from the signal path and has no effect on the frequency response. With the switch depressed (ON), the associated filter operates to attenuate the response above the selected HIGH points of 9 kHz or 20 kHz, or below the selected LOW points of 10 Hz or 40 Hz, at a 12 dB/octave rate, so that unwanted noise components are substantially reduced.

Select the desired cutoff frequency with the associated switch.

**LOW 10 Hz (depressed):** If subsonic noise components are present from the turntable, tape recorder motor, etc., the audible range frequencies may be modulated and cause irritating intermodulation (IM) distortion. This subsonic filter is ideal for eliminating such possible causes of IM distortion without affecting the audible range frequencies, and also prevents speaker damage caused by inadvertent dc content signal flow.

**LOW 40 Hz (released):** Low frequency noise below 40 Hz, such as the rumble created by turntables, record changers or warped records, is reduced.

**HIGH 9 kHz (released):** HIGH frequency noise above 9 kHz, such as the surface noise of records, or tapes when reproducing old or poor quality recordings, or high frequency distortion in records or tapes, is reduced.

**HIGH 20 kHz (depressed):** If the source program contains extremely high frequency noise, fm stereo pilot signal interference, bias leakage of tape recorders, etc., this filter preserves the tweeter unit (especially a super-tweeter) from accidental damage. The filter reduces ultrasonic response by 12 dB/octave while having no effect on the audible range.

### TURNOVER FREQ Switches

These switches select the "turnover frequency" point, or the frequency at which the BASS (or TREBLE) tone control begins to take effect. You can thereby change the bass (or treble) extremes with a varying degree of effect on the mid-range.

Left one (for bass):

(released) . . . 500 Hz turnover frequency

(depressed) . . . 250 Hz turnover frequency

Right one (for treble)

(released) . . . 2.5 kHz turnover frequency

(depressed) . . . 5 kHz turnover frequency

### TONE Switch

**CANCEL (  released):** Bass and treble tone control circuits are disconnected from the signal path and an absolutely flat frequency response is obtained regardless of the BASS and TREBLE control settings.\*

**ON (  depressed):** The BASS and TREBLE controls work normally.

\* The response is still subject to the action of the HIGH and LOW FILTERS and these must be in their OFF positions for a flat response.

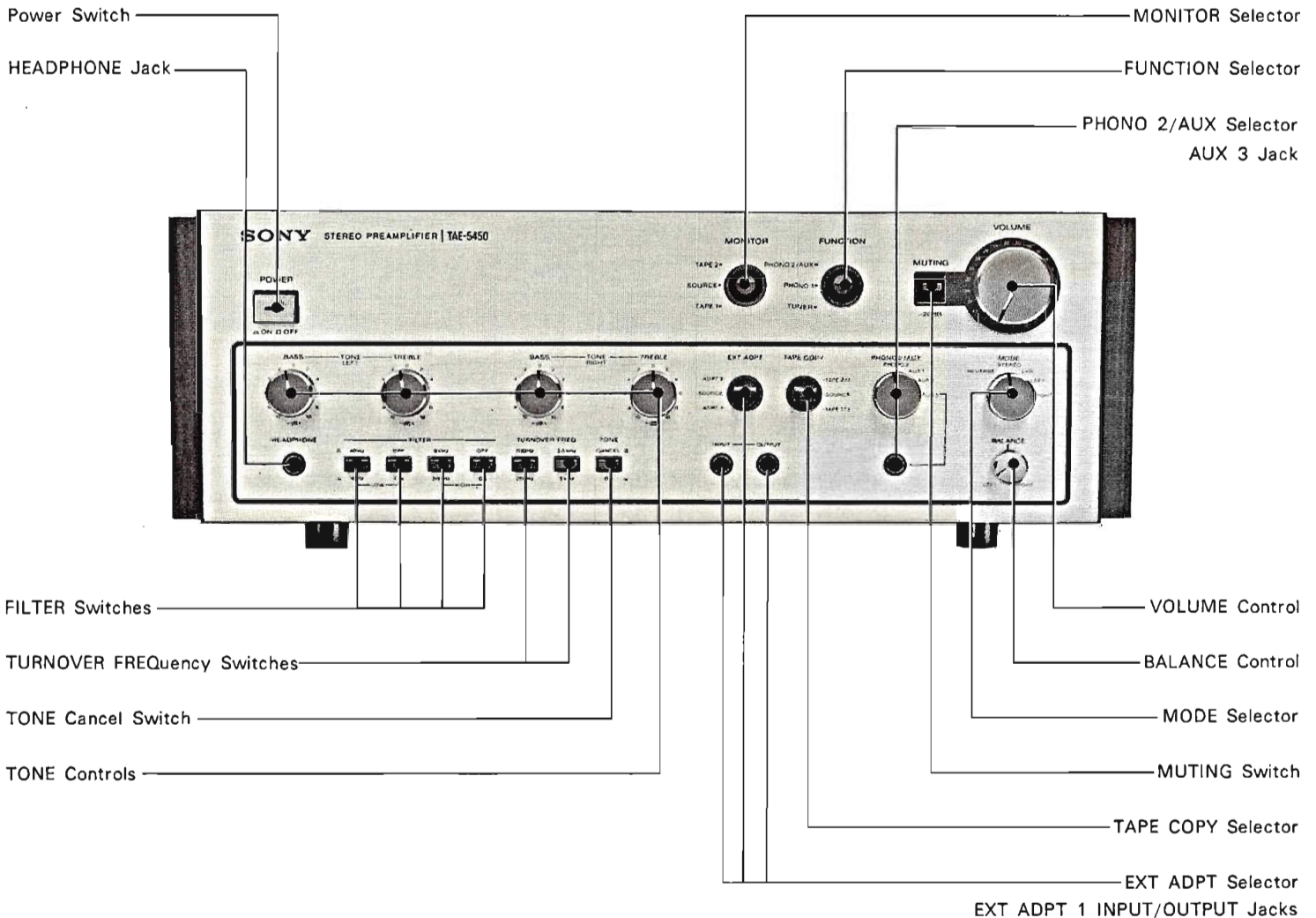



## TONE Controls

Tone controls are useful for correcting any deficiency in your speaker system or listening room acoustics, as well as improperly equalized program source material, and so forth.

These two controls for each channel have a response range of  $\pm 10$  dB in 2 dB steps. When both are in their center position, a flat response results, the same as when the TONE switch is at CANCEL.\*

These controls should be used with discretion, since their over-use may cause an exaggerated frequency response.

**BASS:** Clockwise rotation boosts and counterclockwise rotation reduces bass frequencies above and below a turnover point (250 Hz or 500 Hz) respectively.

**TREBLE:** Clockwise rotation boosts and counterclockwise rotation reduces treble frequencies above and below a turnover point (2.5 kHz or 5 kHz) respectively.

## INPUT SELECTION SECTION

### AUX 3 Jack

Accepts a binaural phone plug to permit a front panel connection of any suitable auxiliary signal source.

### PHONO 2/AUX Selector

When this selector is used, the FUNCTION selector should be set at PHONO 2/AUX position.

**PHONO 2:** For disc programs from record player 2.

**AUX 1–3:** For up to three auxiliary programs, set the selector to the corresponding numbered position.

### MONITOR Selector

**TAPE 2:** For playback of taped programs connected to the TAPE RECORDER 2 connector.

**SOURCE:** For all other program sources (AUX, PHONO, TUNER), set the selector to this position.

**TAPE 1:** For playback of taped programs connected to the TAPE RECORDER 1 connector.

### FUNCTION Selector

**PHONO 2/AUX:** For disc programs from record player 2 (connected to the PHONO 2 inputs) or for auxiliary program, set the selector to this position, and set the PHONO 2/AUX selector (located just below the VOLUME control) to the proper position.

**PHONO 1:** For disc programs from a record player 1 (connected to the PHONO 1 inputs), set the selector to this position.

**TUNER:** For off-the-air programs (connected to the TUNER inputs), set the selector to this position.

## ADD-ON ACCESSORY SECTION

### TAPE COPY Selector

For normal operation, keep this selector at SOURCE position.

By positioning this selector to TAPE 2→1 or TAPE 1→2, you can dub from one tape recorder to another, while still listening to the program source selected with the FUNCTION selector.

**TAPE 2→1:** For dubbing from tape recorder 2 (for playback) to tape recorder 1 (for recording).

**SOURCE:** For normal use. In this position, a PHONO, TUNER, or AUX program signal selected by the FUNCTION selector is routed to both REC OUT 1 and 2, and allows you to record onto two tape recorders simultaneously.

**TAPE 1→2:** For dubbing from tape recorder 1 (for playback) to tape recorder 2 (for recording).

For dubbing from tape recorder 2 to tape recorder 1

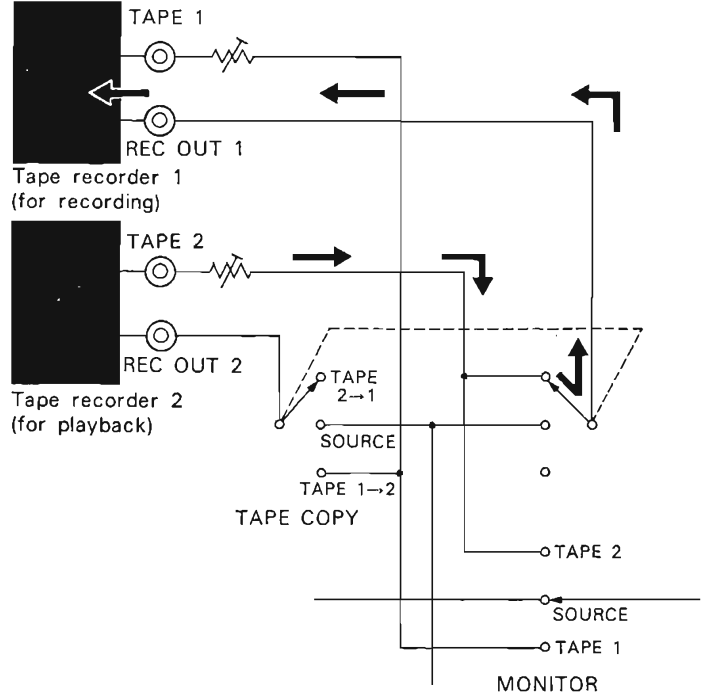

### EXT ADPT Selector (External Adaptor Selector)

For normal operation, keep this selector at SOURCE position.

By placing it to either the ADPT 2 or ADPT 1 position, add-on adaptors (such as a graphic equalizer, SQ adaptor or a third tape recorder, etc.) can be used.

**ADPT 2:** For the use of add-on adaptors connected to the EXT ADPT 2 jacks on the rear panel.

**SOURCE:** For normal use.

**ADPT 1:** For the use of add-on adaptors connected to the EXT ADPT 1 jacks on the front panel. Use a binaural-plug cord for this connection.

For using EXT ADPT 1

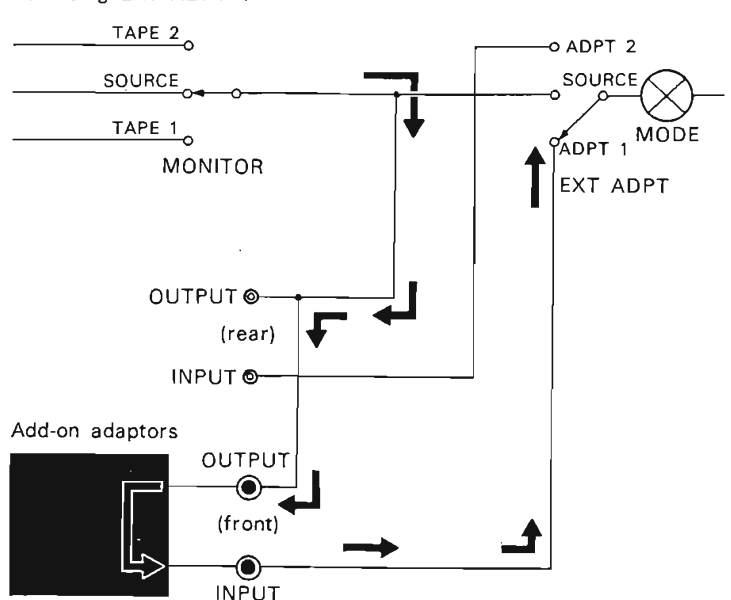

## EXTERNAL ADAPTOR CONNECTORS

Two pairs of EXT ADPT jacks are provided—EXT ADPT 1 on the front panel and EXT ADPT 2 on the rear panel.

These jacks accept an add-on adaptor such as a graphic equalizer, speaker equalizer, SQ adaptor (for a quadraphonic sound setup), or a third tape recorder.

Connect the EXT ADPT OUTPUT jacks to the inputs of the add-on equipment and the EXT ADPT INPUT jacks to the outputs of the equipment.

●When using these jacks, be sure to set the front panel EXT ADPT selector to its proper position. When not in use, set it to SOURCE. If these precautions are not observed, the signal path is not completed and no sound will be heard.

With an SQ decoder

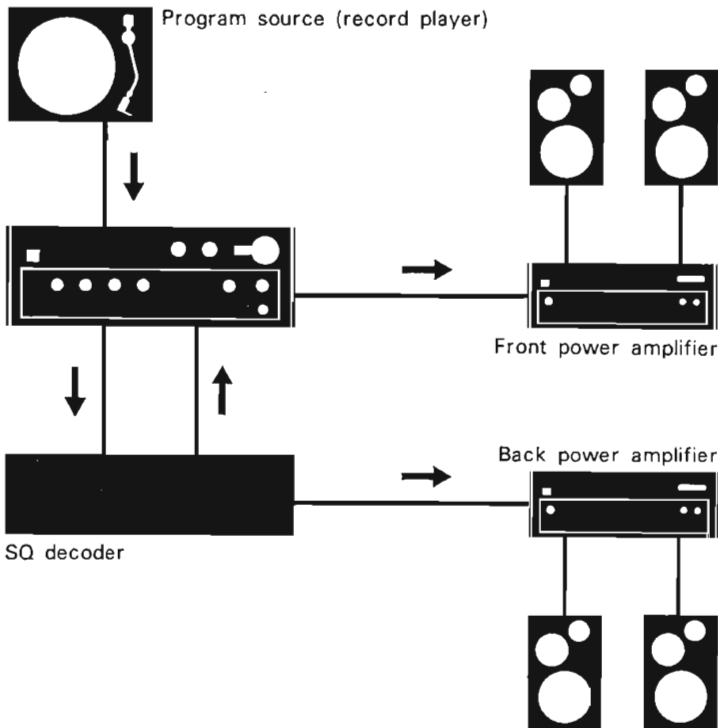

## CARE OF YOUR EQUIPMENT

### TROUBLE CHECKS

If any problem arises with the operation of TAE-5450, check the following chart to help in isolating the trouble. If the trouble persists after you have made these checks, consult your Sony dealer.

#### No audio and the POWER lamp not lit

Check that the ac power cord is plugged into a working outlet.

#### No audio but the POWER lamp lights

Turn up the volume.

Set the MONITOR selector to SOURCE for program sources other than TAPE inputs.

Check the settings of FUNCTION and PHONO 2/AUX selectors.

Check the EXT ADPT selector to see if it is correctly set.

#### No speaker audio when headphone is inserted

When using the HEADPHONE jack, the OUTPUT 2 is disconnected.

#### Low sound level

Set the MUTING switch to upper position.

#### Unbalanced left and right volume

Adjust the BALANCE control.

Check the level or balance controls of the signal source.

#### Unbalanced level between a taped program and another source

Adjust the LEVEL ADJ controls for equal level.

#### No tone control adjustment

Set the TONE switch to ON.

#### No tape copying

Check the TAPE COPY selector to see if it is correctly set.

#### Reversed left and right sound

Check the MODE selector.

#### Distorted sound when setting the preamplifier volume to high levels

Power handling capacity of the connected speaker may be low.

Power amplifier may be overloading (clipping).

#### Severe hum or noise

Use the shielded connecting cords.

Keep the connecting cord away from transformers or motors and at least 3 meters (10 feet) from TV sets and fluorescent lights.

#### Rustling noise

Make secure connections.

Wipe the plugs and jacks with a cloth lightly dampened with methanol.

### CLEANING

Clean the cabinet, panel and knobs periodically with a soft cloth. If finger prints, food and beverage stains, etc. are difficult to remove, use a cloth moistened with a mild detergent solution. Do not use any type of scouring powder, abrasive pad or solvent, since these will damage the cabinet.

# SPECIFICATIONS

## Inputs

	Sensitivity	Impedance	Maximum input capability (0.1% distortion)	S/N (weighting network, input level)
PHONO 1, 2	1.5 millivolts	50,000 ohms	140 millivolts	70 dB (A, 1.5 millivolts)
TUNER AUX 1-3 TAPE 1, 2 EXT ADPT 1, 2	150 millivolts	50,000 ohms	—	90 dB (A, 150 millivolts)

## Outputs

	Voltage	Impedance
REC OUT 1, 2	150 millivolts (max. 12 volts)	1,000 ohms
EXT ADPT 1, 2	150 millivolts (max. 12 volts)	1,000 ohms
HEADPHONE	300 millivolts (8-ohm headphones)	50 ohms
OUTPUT 1	1.0 volt (max. 14 volts)	1,000 ohms
2		2,000 ohms

## Voltage amplification

(at 1 kHz)

Inputs	Outputs			
	REC OUT 1, 2	EXT ADPT 1, 2	HEADPHONE	OUTPUT 1, 2
PHONO 1, 2	40 dB	40 dB	48 dB	58 dB
TUNER AUX 1-3 TAPE 1, 2 EXT ADPT 1, 2	0 dB	0 dB	8 dB	18 dB

Harmonic distortion Less than 0.03% at rated output  
 Intermodulation (IM) distortion Less than 0.05% at rated output  
 (60 Hz : 7 kHz = 4 : 1)  
 Frequency response PHONO 1, 2 RIAA equalization curve  $\pm 0.4$  dB  
 TUNER  
 AUX 1-3  
 TAPE 1, 2  
 EXT ADPT 1, 2 ) 10 Hz -  
 100,000 Hz  $\begin{matrix} +0 \\ -1 \end{matrix}$  dB

## Tone controls

BASS  
 $\pm 10$  dB at 50 Hz  
 (TURNOVER 250 Hz)  
 $\pm 10$  dB at 100 Hz  
 (TURNOVER 500 Hz)  
 TREBLE  
 $\pm 10$  dB at 10,000 Hz  
 (TURNOVER 2,500 Hz)  
 $\pm 10$  dB at 20,000 Hz  
 (TURNOVER 5,000 Hz)

## Filters

LOW  
 12 dB/octave attenuation below  
 10 Hz or 40 Hz  
 HIGH  
 12 dB/octave attenuation above  
 9,000 Hz or 20,000 Hz

## Residual noise

Less than 200 microvolts (70 microvolts below 20,000 Hz), with VOLUME set to minimum, TONE canceled, FILTERS off

## General System

Equalizer amplifier: a unit amplifier\*  
 Flat and tone control amplifier: a unit amplifier\*

Filter amplifier: 2 transistors

Headphone amplifier: 1 IC

## Semiconductors

2 ICs, 16 FETs, 36 transistors, 12 diodes

## Power requirements

120 V ac, 60 Hz

## Power consumption

9 watts

## AC outlets

2 switched 300 watts,  
 1 unswitched 200 watts

## Dimensions

Approx. 460 (w)  $\times$  168 (h)  $\times$  323 (d) mm  
 (18 1/8  $\times$  6 5/8  $\times$  12 3/4 inches)  
 including projecting parts and controls

## Weight

Approx. 9.2 kg (20 lb 5 oz) net  
 Approx. 11.6 kg (25 lb 9 oz) in shipping carton

## Supplied accessories

Shorting plugs (4)  
 Connecting cord RK-74H (2)  
 Connecting cord RK-81H (1)

Design and specifications subject to change without notice.

\* A unit amplifier consists of a dual FET differential input, 2 PNP transistors differential amplifier and FET-PNP transistor complementary output.

# BLOCK DIAGRAM

